



北京首钢股份有限公司
BEIJING SHOUGANG CO., LTD.

酸洗汽车用钢 产品手册

PICKLED AUTOMOTIVE STEEL MANUAL



北京首钢股份有限公司
Beijing Shougang Co., Ltd.

CONTENTS / 目录

第一章 首钢酸洗汽车用钢产品

产品类别	01
工艺流程	02
热轧酸洗机组简介	02

第二章 产品介绍

冷成型用钢	04
汽车结构用低合金高强钢	06
汽车车轮用钢	10
汽车大梁用钢	13
先进高强钢	15
热成形钢	18

第三章 产品规格及尺寸精度

20

第四章 质量保障

22

第五章 包装与标识

热连轧酸洗钢带包装方式	24
热连轧酸洗钢板的包装方式	27

附录

联系方式	30
产品商标介绍	31

Chapter 1 Pickled Automotive Steel Product of Shougang Steel

第一章 首钢酸洗汽车用钢产品

1.1 产品类别

Product category

首钢酸洗产品以迁钢、京唐两个生产基地为依托，在首钢技术研究院及技术中心支撑下，积累了丰富的生产、技术及品质管理经验。首钢酸洗产品具有稳定可靠、产品尺寸精度高、板形控制良好等诸多特点，产品质量广受用户认可，具有良好的市场美誉度。

热轧酸洗产品以高表面质量、低工序成本、高尺寸精度等优势，被广泛应用于汽车行业，成为汽车底盘、座椅、车轮、安全构件等主要材料。

2009 年至今，首钢已成长为国内完全依靠自主创新，形成高端汽车用酸洗板生产能力的钢铁企业，拥有配套的酸洗产品研发、生产、供应能力，可以向用户提供全套的解决方案。

首钢积极开展汽车的轻量化、低碳化的绿色制造工作，愿与客户共同开展、分享减少碳足迹，拓展绿色环保产品，向社会提供环境友好的产品和服务。

Shougang pickled products rely on Qiangang base and Jingtang base, with the support of Shougang Technology Research Institute and Technology Center, Shougang pickled products have accumulated rich experience in production, technology and quality management.

Hot-rolled pickled products are widely used in the automotive industry due to the advantages of high surface quality, low process composition, and high dimensional accuracy, and become the main materials for automobile chassis, seats, wheels, and safety components.

Shougang has grown into a domestic steel enterprise that completely relies on independent innovation to form a high-end automotive pickled board production capacity since 2009. It has supporting pickled product research and development, production and supply capabilities, and can provide users with a complete set of solutions.

Shougang is actively engaged in the lightweight and low-carbon green manufacturing of automobiles, and is willing to jointly carry out and share with customers to reduce carbon footprint, expand green and environmentally friendly products, and provide the society with environmentally friendly products and services.

1.2 工艺流程 Process flow

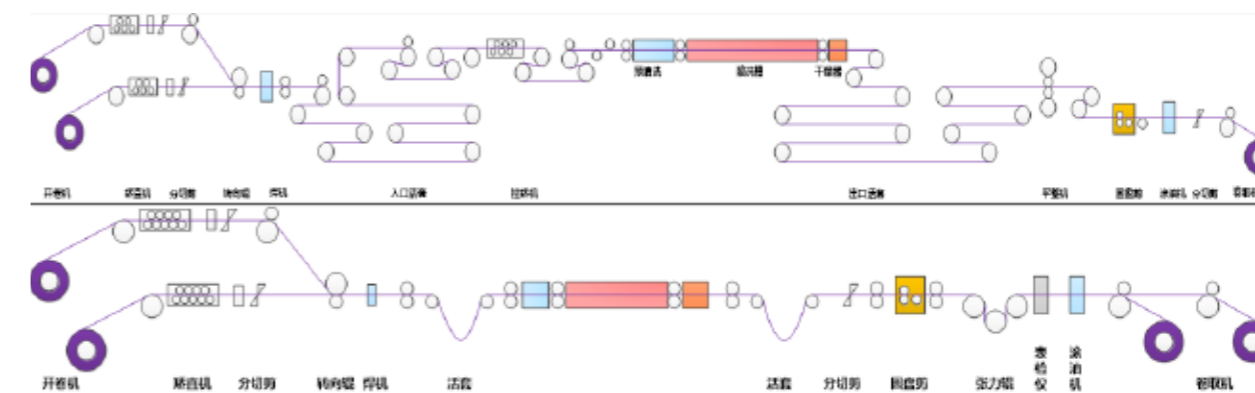

1.3 热轧酸洗机组简介 Introduction to pickling unit

首钢目前共计 4 条热轧酸洗板生产机组，具备 377 万吨酸洗板生产能力，其中迁钢基地连续式酸洗机组、京唐基地连续式酸洗机组均于 2020 年相继投产，引入激光焊接、在线拉矫破鳞、紊流酸洗、在线平整、在线拉矫、切边、涂油等工序。

Shougang currently has 4 pickling production lines with a production capacity of 3.77 million tons of pickled plate. Among them, the continuous pickling line at Qiangang Base and the continuous pickling line at Jingtang Base were put into operation one after another in 2020, introducing laser welding and online Stretching and correcting scales, turbulent flow pickling, online leveling, online tensioning, trimming, oiling and other processes.

首钢在线汽车板使用性能数据库覆盖 1200MPa 级别及以下汽车板牌号，内容包含化学成分、金相组织、力学性能、成形性能、碰撞性能、疲劳性能等，可满足汽车厂认证和选材的需求，为汽车企业提供准确的材料成形仿真数据。

Shougang online automotive steel performance database covers grades up to 1200MPa, including chemical composition, metallurgical structure, mechanical properties, forming properties, crash performance, fatigue performance, etc. It can meet the requirements of auto factory certification and material selection, and provide accurate material forming simulation data for auto enterprises.

序号 Number	分类 Category	项目 Item	迁钢 1# 酸洗机组 Qiangang 1# Pickling unit	迁钢 2# 酸洗机组 Qiangang 2# Pickling unit	京唐高强连续式酸洗机组 Jingtang high-strength continuous pickling unit
1	产品设计 Design of product	厚度范围 Thickness range	1.5-8.0mm	1.2-8.0mm	0.8-7.0mm
2		宽度范围 Width range	700-1600mm	800-1630mm	750-1630mm
3		强度范围 Strength range	≤ 1000Mpa	≤ 1200Mpa	≤ 1000Mpa
4		年产能 Annual production capacity	80 万吨 800,000 tons	95 万吨 950,000 tons	150 万吨 1500,000 tons
5		工艺段速度 Speed of process	≤ 180m/min	≤ 180m/min	≤ 320m/min
6		单卷重量 Coil weight	≤ 30 吨 ≤ 30 tons	≤ 30 吨 ≤ 30 tons	≤ 33.6 吨 ≤ 33.6 tons
7	矫直设备 Straightening equipment	拉矫机结构 Construction of scale breaker	离线 50 吨拉矫 Max elongation force:50 tons Offline	在线 65 吨拉矫 Max elongation force:65 tons Online	在线 75 吨拉矫 Max elongation force:75 tons Online
8		平整机结构 Construction of temper mill	—	立式 50 吨 30tons Vertical	四辊湿式 1500 吨 Temper mill type:4Hi Wet Max Temper Mill force:1500 Tons
9		张力矫直机 Construction of tension Levelling	—	—	普锐特: 6 辊湿式 60 吨 Primetals :6Hi Wet
10	主体设备 Main facility	开卷 / 卷取 Pay off reel/tension reel	双开双卷 Double decoiler and double coiler	双开双卷 Double decoiler and double coiler	双开双卷 Double decoiler and double coiler
11		焊机 Welding machine	埋弧焊 Arc-submerging welder	全自动激光焊 Laser Welder	全自动激光焊 Laser Welder
12		酸洗段长度 Length of pickling section	五段 65m Five (5) chambers 65m	三段 78m Three(3) chambers 78m	五段 100 米 Five (5) chambers 100m
13		漂洗水段 Length of rinsing section	五段 3.25m Five (5) chambers 3.25m	五段 5m Five (5) chambers 5m	五段 13.6m Five (5) chambers 13.6m
14		圆盘剪 Side-trimmer	单塔 Single turret type	双塔旋转 Single turret and rotary type	双塔旋转 Single turret and rotary type
15		涂油 Oiling machine	静电涂油 Electrostatic oiler	静电涂油 Electrostatic oiler	静电涂油 Electrostatic oiler
16	检验设备 Inspection equipment		在线百事泰 1 台 1 online Parsytec 在线边降仪 1 台 1 online edge drop instrument	在线百事泰 3 台 3 online Parsytec	在线百事泰 1 台 1 online Parsytec

Chapter 2 Product Introduction

第二章 产品介绍

2.1 冷成型用钢 Cold forming steel

冷成型就是在不加热的情况下对材料进行冲剪、弯曲、拉伸等加工方式。冷成型工艺有锻压、滚轧、冲压等。冷成型用钢具有良好的冲压性能、焊接性能和较高的尺寸精度，按照其用途可以分为一般用、冲压用、深冲用和超深冲用，如家电外壳、汽车刹车片、离合器等零部件。

Cold forming is the process of punching, shearing, bending and stretching materials without heating. The cold forming process includes forging, rolling, stamping and so on. Cold forming steel has good stamping performance, welding performance and high dimension precision. According to its use, it can be divided into commercial purpose, drawing, deep drawing and extra-deep drawing, such as home appliance shell, automobile brake pad, clutch and other parts.

2.1.1 牌号标准 Grade and standard

首钢企业标准 Shougang standard		相当国家 / 国际标准 National/International standard								
标准号 Standard	牌号 Grade	标准号 Standard	牌号 Grade	标准号 Standard	牌号 Grade	标准号 Standard	牌号 Grade			
Q/SGZGS 0314	SPHC	JIS G 3131	SPHC	-	-	-	-			
	SPHD		SPHD							
	SPHE		SPHE							
	SPHF		SPHF							
	DD11	EN 10111	DD11					StW22	ISO 3573	HR1
	DD12		DD12					StW23		HR2
	DD13		DD13					StW24		HR3
DD14	DD14		-	-						

2.1.2 化学成分 Chemical composition

牌号 Grade	化学成分 (熔炼分析) Chemical composition (Ladle analysis) / %					
	C ≤	Si ≤	Mn ≤	P ≤	S ≤	Alt ≥
SPHC、DD11	0.12	0.05	0.60	0.035	0.030	0.010
SPHD、DD12	0.08	0.05	0.45	0.030	0.025	
SPHE、DD13	0.06	0.05	0.40	0.025	0.020	
SPHF、DD14	0.06	0.05	0.35	0.020	0.020	

2.1.3 力学性能 Mechanical Properties

牌号 Grade	拉伸试验 Tensile test							180°弯曲试验 180° Bending test	
	抗拉强度 Tensile strength R _m /MPa	下列厚度 (mm) 的断后伸长率 Elongation as follow normal thickness, A _{50mm} /%						下列厚度 (mm) 的弯曲直径 Inner diameters as follow normal thickness	
		< 1.6	1.6 ~ < 2.0	2.0 ~ < 2.5	2.5 ~ < 3.2	3.2 ~ < 4.0	≥ 4.0	< 3.2	≥ 3.2
SPHC	≥ 270	≥ 27	≥ 29	≥ 29	≥ 29	≥ 31	≥ 31	D=0	D=1a
SPHD	≥ 270	≥ 30	≥ 32	≥ 33	≥ 35	≥ 37	≥ 39	—	—
SPHE	≥ 270	≥ 32	≥ 34	≥ 35	≥ 37	≥ 39	≥ 41	—	—
SPHF	≥ 270	≥ 37	≥ 38	≥ 39	≥ 39	≥ 40	≥ 42	—	—

牌号 Grade	拉伸试验 Tensile test							性能保证期 Guarantee period
	抗拉强度 Tensile strength R _m / MPa	下列厚度 (mm) 的上屈服强度 upper yield strength as follow normal thickness R _{eL} / MPa		下列厚度 (mm) 的断后伸长率 Elongation as follow normal thickness				
		< 2.0	2.0 ~ 11.0	A _{80mm} /%		A /%		
DD11	≤ 440	170 ~ 360	170 ~ 340	≥ 22	≥ 23	≥ 24	≥ 28	
DD12	≤ 420	170 ~ 340	170 ~ 320	≥ 24	≥ 25	≥ 26	≥ 30	6个月 6 months
DD13	≤ 400	170 ~ 330	170 ~ 310	≥ 27	≥ 28	≥ 29	≥ 33	6个月 6 months
DD14	≤ 380	170 ~ 310	170 ~ 290	≥ 30	≥ 31	≥ 32	≥ 36	6个月 6 months

2.1.4 可订货规格 Available size

生产基地 Base	名称 Name			公称厚度 Nominal thickness/mm	公称宽度 Nominal width/mm
	首钢企业标准 Shougang standard	相当国家 / 国际标准 National/International standard	牌号 Grade		
迁钢基地 Qiangang base	Q/SGZGS 0314	JIS G 3131	SPHC、SPHD、SPHE、SPHF	1.5-8.0	750-1600
		EN 10111	DD11、DD12、DD13、DD14	1.5-8.0	750-1600
		DIN1614-2	StW22、StW23、StW24	1.5-8.0	750-1600
		ISO 3573	HR1、HR2、HR3	1.5-8.0	750-1600
京唐基地 Jingtang base		JIS G 3131	SPHC、SPHD、SPHE、SPHF	0.8-7.0	750-1630
		EN 10111	DD11、DD12、DD13、DD14	0.8-7.0	750-1630
		DIN1614-2	StW22、StW23、StW24	0.8-7.0	750-1630
		ISO 3573	HR1、HR2、HR3	0.8-7.0	750-1630

2.2 汽车结构用低合金高强度钢 HSLA steel for automobile structure

具有良好成型性能，主要用于制造汽车大梁、构架、滚型车轮等汽车结构件。

HSLA steel has good forming properties and is mainly used to manufacture automobile structural parts such as girders, frames, and roller wheels.

2.2.1 牌号标准 Grade and standard

首钢企业标准 Shougang standard		相当国家 / 国际标准 National/International standard		
标准号 Standard	牌号 Grade	标准号 Standard	牌号 Grade	
Q/SGZGS 0315	S315MC	EN 10149-2	S315MC	
	S355MC		S355MC	
	S420MC		S420MC	
	S460MC		S460MC	
	S500MC		S500MC	
	S550MC		S550MC	
	S600MC		S600MC	
	S650MC		S650MC	
	S700MC		S700MC	
	QStE340TM		SEW 092	QStE340TM
	QStE380TM	QStE380TM		
	QStE420TM	QStE420TM		
	QStE460TM	QStE460TM		
	QStE500TM	QStE500TM		
	QStE550TM	QStE550TM		
	SAPH310	JIS G 3113		SAPH310
	SAPH370			SAPH370
	SAPH400			SAPH400
	SAPH440			SAPH440
	SPFH490	JIS G 3134	SPFH490	
SPFH540	SPFH540			
SPFH590	SPFH590			
SPFH540Y	SPFH540Y			
SPFH590Y	SPFH590Y			

2.2.2 化学成分 Chemical composition

牌号 Grade	化学成分 (熔炼分析) / % Chemical composition (Ladle analysis)					
	C	Si	Mn	P	S	Alt
SAPH310	≤ 0.12	≤ 0.30	≤ 0.50	≤ 0.025	≤ 0.020	≥ 0.010
SAPH370	≤ 0.12	≤ 0.30	≤ 1.20	≤ 0.025	≤ 0.020	≥ 0.010
SAPH400	≤ 0.12	≤ 0.30	≤ 1.40	≤ 0.025	≤ 0.020	≥ 0.010
SAPH440	≤ 0.12	≤ 0.30	≤ 1.60	≤ 0.025	≤ 0.020	≥ 0.010

牌号 Grade	化学成分 (熔炼分析) / % Chemical composition (Ladle analysis)					
	C	Si	Mn	P	S	Alt
SPFH490	≤ 0.15	≤ 0.50	≤ 1.60	≤ 0.025	≤ 0.020	≥ 0.015
SPFH540	≤ 0.15	≤ 0.50	≤ 1.80	≤ 0.025	≤ 0.020	≥ 0.015
SPFH590	≤ 0.18	≤ 0.60	≤ 2.00	≤ 0.025	≤ 0.020	≥ 0.015
SPFH540Y	≤ 0.15	≤ 0.60	≤ 1.80	≤ 0.025	≤ 0.020	≥ 0.015
SPFH590Y	≤ 0.15	≤ 0.60	≤ 1.80	≤ 0.025	≤ 0.020	≥ 0.015

牌号 Grade	化学成分 (熔炼分析) , % Chemical composition (Ladle analysis)										
	C	Si	Mn	P	S	Alt	Nb ^a	V ^a	Ti ^a	Mo	B
S315MC	≤ 0.12	≤ 0.50	≤ 1.30	≤ 0.025	≤ 0.020	≥ 0.015	≤ 0.09	≤ 0.20	≤ 0.15	--	--
S355MC	≤ 0.12	≤ 0.50	≤ 1.50	≤ 0.025	≤ 0.020	≥ 0.015	≤ 0.09	≤ 0.20	≤ 0.15	--	--
S420MC	≤ 0.12	≤ 0.50	≤ 1.60	≤ 0.025	≤ 0.015	≥ 0.015	≤ 0.09	≤ 0.20	≤ 0.15	--	--
S460MC	≤ 0.12	≤ 0.50	≤ 1.60	≤ 0.025	≤ 0.015	≥ 0.015	≤ 0.09	≤ 0.20	≤ 0.15	--	--
S500MC	≤ 0.12	≤ 0.50	≤ 1.70	≤ 0.025	≤ 0.015	≥ 0.015	≤ 0.09	≤ 0.20	≤ 0.15	--	--
S550MC	≤ 0.12	≤ 0.50	≤ 1.80	≤ 0.025	≤ 0.015	≥ 0.015	≤ 0.09	≤ 0.20	≤ 0.15	--	--
S600MC	≤ 0.12	≤ 0.50	≤ 1.90	≤ 0.025	≤ 0.015	≥ 0.015	≤ 0.09	≤ 0.20	≤ 0.22		≤ 0.005
S650MC	≤ 0.12	≤ 0.60	≤ 2.00	≤ 0.025	≤ 0.015	≥ 0.015	≤ 0.09	≤ 0.20	≤ 0.22	≤ 0.5	≤ 0.005
S700MC	≤ 0.12	≤ 0.60	≤ 2.10	≤ 0.025	≤ 0.015	≥ 0.015	≤ 0.09	≤ 0.20	≤ 0.22		≤ 0.005

牌号 Grade	化学成分 (熔炼分析) , % Chemical composition (Ladle analysis)							
	C	Si	Mn	P	S	Alt	Nb	Ti
QStE340TM	≤ 0.12	≤ 0.50	≤ 1.30	≤ 0.025	≤ 0.020	≥ 0.015	≤ 0.09	≤ 0.22
QStE380TM	≤ 0.12	≤ 0.50	≤ 1.40	≤ 0.025	≤ 0.020	≥ 0.015	≤ 0.09	≤ 0.22
QStE420TM	≤ 0.12	≤ 0.50	≤ 1.50	≤ 0.025	≤ 0.015	≥ 0.015	≤ 0.09	≤ 0.22
QStE460TM	≤ 0.12	≤ 0.50	≤ 1.60	≤ 0.025	≤ 0.015	≥ 0.015	≤ 0.09	≤ 0.22
QStE500TM	≤ 0.12	≤ 0.50	≤ 1.70	≤ 0.025	≤ 0.015	≥ 0.015	≤ 0.09	≤ 0.22
QStE550TM	≤ 0.12	≤ 0.50	≤ 1.80	≤ 0.025	≤ 0.015	≥ 0.015	≤ 0.09	≤ 0.22

牌号 Grade	化学成分 (熔炼分析) , % Chemical composition (Ladle analysis)										
	C	Si	Mn	P	S	Alt	Nb	V	Ti	Mo	B
QStE600TM	≤ 0.12	≤ 0.50	≤ 1.90								
QStE650TM	≤ 0.12	≤ 0.60	≤ 2.00	≤ 0.025	≤ 0.015	≥ 0.015	≤ 0.09	≤ 0.20	≤ 0.22	≤ 0.5	≤ 0.005
QStE700TM	≤ 0.12	≤ 0.60	≤ 2.10								



2.2.3 力学性能 Mechanical Properties

牌号 Grade	拉伸试验 Tensile test										弯曲试验 180° 180° bend test	
	抗拉强度 Tensile strength R _m /MPa	下列厚度的上屈服强度 upper yield strength as follow thickness R _{eH} /MPa			下列厚度的断后伸长率 Elongation as follow normal thickness A _{50mm} / %							
		公称厚度 mm Nominal thickness			公称厚度 mm Nominal thickness						公称厚度 mm Nominal thickness	
		< 6.0	6.0 ~ < 8.0	8.0 ~ < 14.0	< 2.0	2.0 ~ < 2.5	2.5 ~ < 3.15	3.15 ~ < 4.0	4.0 ~ < 6.3	≥ 6.3	< 2.0	≥ 2.0
SAPH310	≥ 310	≥ 185	≥ 185	≥ 175	≥ 33	≥ 34	≥ 36	≥ 38	≥ 40	≥ 41	D=0a	D=2a
SAPH370	≥ 370	≥ 225	≥ 225	≥ 215	≥ 32	≥ 33	≥ 35	≥ 36	≥ 37	≥ 38	D=a	D=2a
SAPH400	≥ 400	≥ 255	≥ 235	≥ 235	≥ 31	≥ 32	≥ 34	≥ 35	≥ 36	≥ 37	D=2a	D=2a
SAPH440	≥ 440	≥ 305	≥ 295	≥ 275	≥ 29	≥ 30	≥ 32	≥ 33	≥ 34	≥ 35	D=2a	D=2a

牌号 Grade	上屈服强度 R _{eH} / MPa Upper yield strength R _{eH} /MPa	抗拉强度 R _m / MPa Tensile strength R _m /MPa	断后伸长率 A _{50mm} / % Elongation				弯曲试验 180° 180° bend test	
			公称厚度 mm Nominal thickness					
			< 2.0	2.0 ~ < 2.5	2.5 ~ < 3.25	3.25 ~ 8.0	< 3.25	≥ 3.25
SPFH490	≥ 325	≥ 490	≥ 22	≥ 23	≥ 24	≥ 25	D=a	D=2a
SPFH540	≥ 355	≥ 540	≥ 21	≥ 22	≥ 23	≥ 24	D=2a	D=3a
SPFH590	≥ 420	≥ 590	≥ 19	≥ 20	≥ 21	≥ 22	D=3a	D=3a
SPFH540Y	≥ 295	≥ 540	—	≥ 24	≥ 25	≥ 26	D=2a	D=3a
SPFH590Y	≥ 325	≥ 590	—	≥ 22	≥ 23	≥ 24	D=3a	D=3a

牌号 Grade	拉伸试验 Tensile test				弯曲试验 180° 180° bend test
	上屈服强度 R _{eH} /MPa Upper yield strength R _{eH} /MPa	抗拉强度 R _m /MPa Tensile strength R _m /MPa	断后伸长率 Elongation		
			A _{80mm} / % 公称厚度 < 3mm Nominal thickness < 3mm	A / % 公称厚度 ≥ 3mm Nominal thickness ≥ 3mm	
S315MC	≥ 315	390 ~ 510	≥ 20	≥ 24	D=0a
S355MC	≥ 355	430 ~ 550	≥ 19	≥ 23	D=0.5a
S420MC	≥ 420	480 ~ 620	≥ 16	≥ 19	D=0.5a
S460MC	≥ 460	520 ~ 670	≥ 14	≥ 17	D=1a
S500MC	≥ 500	550 ~ 700	≥ 12	≥ 14	D=1a
S550MC	≥ 550	600 ~ 760	≥ 12	≥ 14	D=1.5a
S600MC	≥ 600	650 ~ 820	≥ 11	≥ 13	D=1.5a
S650MC	≥ 650	700 ~ 880	≥ 10	≥ 12	D=2a
S700MC	≥ 700	750 ~ 950	≥ 10	≥ 12	D=2a

牌号 Grade	拉伸试验 Tensile test				弯曲试验 180° 180° bend test
	上屈服强度 R _{eH} /MPa Upper yield strength R _{eH} /MPa	抗拉强度 R _m /MPa Tensile strength R _m /MPa	断后伸长率 Elongation		
			A _{80mm} / % 公称厚度 < 3mm Nominal thickness < 3mm	A / % 公称厚度 ≥ 3mm Nominal thickness ≥ 3mm	
QStE340TM	≥ 340	420 ~ 540	≥ 19	≥ 25	D=0.5a
QStE380TM	≥ 380	450 ~ 590	≥ 18	≥ 23	D=0.5a
QStE420TM	≥ 420	480 ~ 620	≥ 16	≥ 21	D=0.5a
QStE460TM	≥ 460	520 ~ 670	≥ 14	≥ 19	D=1a
QStE500TM	≥ 500	550 ~ 700	≥ 12	≥ 17	D=1a
QStE550TM	≥ 550	600 ~ 760	≥ 12	≥ 15	D=1.5a
QStE600TM	≥ 600	650 ~ 820	≥ 11	≥ 13	D=1.5a
QStE650TM	≥ 650	700 ~ 880	≥ 10	≥ 12	D=2a
QStE700TM	≥ 700	750 ~ 950	≥ 10	≥ 12	D=2a

2.2.4 可订货规格 Available size

名称 Name			厚度订货范围 /mm Nominal thickness/mm	宽度订货范围 /mm Nominal width/mm
首钢企业标准 Shougang standard	相当国家 / 国际标准 National/International standard	牌号 Grade		
Q/SGZGS 0315	EN 10149-2	S315MC	1.2-7.0	750-1550
		S355MC	1.2-7.0	750-1550
		S420MC、S460MC、S500MC	1.4-6.5	750-1550
		S550MC	1.5-6.5	750-1400
		S600MC	1.5-6.5	750-1400
		S650MC、S700MC	1.5-6.5	750-1400
	SEW 092	QStE340TM	1.2-7.0	750-1550
		QStE380TM、QStE420TM、QStE460TM	1.4-6.5	750-1550
		QStE500TM	1.4-6.5	750-1550
		QStE550TM	1.5-6.5	750-1400
	JIS G 3113	SAPH310	1.2-7.0	750-1635
		SAPH370	1.2-7.0	750-1550
		SAPH400	1.2-7.0	750-1550
		SAPH440	1.2-7.0	750-1550
	JIS G 3134	SPFH490、SPFH540、SPFH590	1.5-6.5	750-1550

2.3 汽车车轮用钢 Wheel steel

具有良好冷成型性能、耐疲劳性能和焊接性能，用于制造钢制汽车轮辐、轮辋。

Wheel steel has good cold forming property, fatigue resistance and welding property. It is used to make spokes and rims of steel automobiles.

2.3.1 牌号标准 Grade and standard

首钢企业标准 Shougang standard	
标准号 Standard	牌号 Grade
Q/SGZGS 0351	S330LW/ S330LF、S380LW/ S380LF、S400LW/ S400LF、S420LW/ S420LF、S440LW/ S440LF、S490LW/ S490LF、S540LW/ S540LF、S590LW/ S590LF、S650LW/ S650LF、S700LW/ S700LF

2.3.2 化学成分 Chemical composition

牌号 Grade	化学成分 (质量分数 /%) Chemical composition(wt%)					
	C	Si	Mn	P	S	Als
S330LW	≤ 0.12	≤ 0.05	≤ 0.50	≤ 0.025	≤ 0.015	≥ 0.010
S380LW	≤ 0.12	≤ 0.15	≤ 1.20	≤ 0.025	≤ 0.015	≥ 0.010
S400LW	≤ 0.14	≤ 0.15	≤ 1.40	≤ 0.025	≤ 0.015	≥ 0.010
S420LW	≤ 0.14	≤ 0.30	≤ 1.40	≤ 0.025	≤ 0.015	≥ 0.010
S440LW	≤ 0.14	≤ 0.30	≤ 1.50	≤ 0.025	≤ 0.015	≥ 0.010
S490LW	≤ 0.15	≤ 0.30	≤ 1.60	≤ 0.025	≤ 0.015	≥ 0.010
S540LW	≤ 0.12	≤ 0.35	≤ 1.70	≤ 0.020	≤ 0.010	≥ 0.010
S590LW	≤ 0.12	≤ 0.50	≤ 1.80	≤ 0.020	≤ 0.010	≥ 0.010
S650LW	≤ 0.12	≤ 0.55	≤ 2.00	≤ 0.020	≤ 0.010	≥ 0.010
S700LW	≤ 0.12	≤ 0.55	≤ 2.10	≤ 0.020	≤ 0.010	≥ 0.010

牌号 Grade	化学成分 (质量分数 /%) Chemical composition(wt%)					
	C	Si	Mn	P	S	Als
S330LF	≤ 0.12	≤ 0.05	≤ 0.50	≤ 0.025	≤ 0.015	≥ 0.010
S380LF	≤ 0.14	≤ 0.15	≤ 1.20	≤ 0.025	≤ 0.015	≥ 0.010
S400LF	≤ 0.16	≤ 0.15	≤ 1.40	≤ 0.025	≤ 0.015	≥ 0.010
S420LF	≤ 0.16	≤ 0.30	≤ 1.40	≤ 0.025	≤ 0.015	≥ 0.010
S440LF	≤ 0.18	≤ 0.30	≤ 1.50	≤ 0.025	≤ 0.015	≥ 0.010
S490LF	≤ 0.18	≤ 0.30	≤ 1.70	≤ 0.025	≤ 0.015	≥ 0.010
S540LF	≤ 0.20	≤ 0.35	≤ 1.70	≤ 0.020	≤ 0.010	≥ 0.010
S590LF	≤ 0.20	≤ 0.50	≤ 1.70	≤ 0.020	≤ 0.010	≥ 0.010
S650LF	≤ 0.20	≤ 0.55	≤ 1.80	≤ 0.020	≤ 0.010	≥ 0.010
S700LF	≤ 0.20	≤ 0.55	≤ 1.90	≤ 0.020	≤ 0.010	≥ 0.010

2.3.3 力学性能 Mechanical Properties

牌号 Grade	拉伸试验 Tensile test			180°弯曲试验 180° bend test
	下屈服强度 R_{eL} /MPa Lower yield strength R_{eL} /MPa	抗拉强度 R_m /MPa Tensile strength R_m /MPa	断后伸长率 A/% Elongation A/%	
S330LW/ S330LF	≥ 225	330 ~ 430	≥ 33.0	D=0.5a
S380LW/ S380LF	≥ 235	380 ~ 480	≥ 28.0	D=1.0a
S400LW/ S400LF	≥ 235	400 ~ 520	≥ 26.0	D=1.0a
S420LW/ S420LF	≥ 290	420 ~ 520	≥ 26.0	D=1.0a
S440LW/ S440LF	≥ 295	440 ~ 550	≥ 26.0	D=1.0a
S490LW/ S490LF	≥ 325	490 ~ 600	≥ 24.0	D=2.0a
S540LW/ S540LF	≥ 355	540 ~ 660	≥ 22.0	D=2.0a
S590LW/ S590LF	≥ 420	590 ~ 710	≥ 20.0	D=2.0a
S650LW/ S650LF	≥ 500	650 ~ 770	≥ 17.0	D=2.0a
S700LW/S700LF	≥ 550	700 ~ 850	≥ 15.0	D=2.0a

2.3.4 可订货规格 Available size

名称 Name	厚度订货范围 /mm Nominal thickness/ mm	宽度订货范围 /mm Nominal width/mm
首钢企业标准 Shougang standard		
Q/SGZGS 0351	1.8-6.0	750-1300

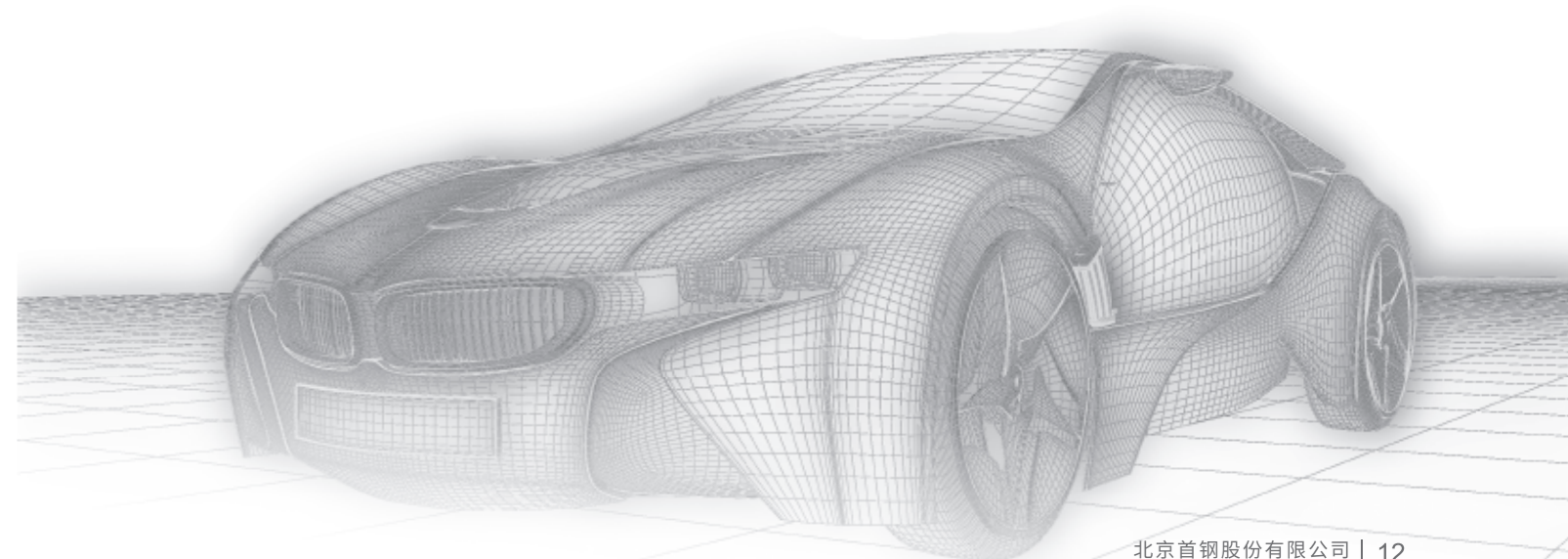

2.4 汽车大梁用钢

汽车大梁用钢具有良好的成型性能，用于制造汽车大梁（纵梁、横梁）。

The steel for automobile frames has good forming properties and is mainly used to manufacture automobile longitudinal frames and cross frames.

2.4.1 牌号标准 Grade and standard

国家标准	
标准号 Standard	牌号 Grade
GB/T 3273	370L、420L、440L、510L、550L、600L、650L、700L、750L、800L

2.4.2 化学成分 Chemical composition

牌号 Grade	化学成分（质量分数/%） Chemical composition(wt%)					
	C	Si	Mn	P	S	Als
370L	≤ 0.12	≤ 0.50	≤ 0.60	≤ 0.025	≤ 0.015	≥ 0.015
420L	≤ 0.12	≤ 0.50	≤ 1.50	≤ 0.025	≤ 0.015	≥ 0.015
440L	≤ 0.18	≤ 0.50	≤ 1.50	≤ 0.025	≤ 0.015	≥ 0.015
510L	≤ 0.20	≤ 0.50	≤ 1.60	≤ 0.025	≤ 0.015	≥ 0.015
550L	≤ 0.20	≤ 0.50	≤ 1.70	≤ 0.025	≤ 0.015	≥ 0.015
600L	≤ 0.12	≤ 0.50	≤ 1.80	≤ 0.025	≤ 0.015	≥ 0.015
650L	≤ 0.12	≤ 0.50	≤ 1.90	≤ 0.025	≤ 0.015	≥ 0.015
700L	≤ 0.12	≤ 0.60	≤ 2.00	≤ 0.025	≤ 0.015	≥ 0.015
750L	≤ 0.12	≤ 0.60	≤ 2.10	≤ 0.025	≤ 0.015	≥ 0.015
800L	≤ 0.12	≤ 0.60	≤ 2.20	≤ 0.025	≤ 0.015	≥ 0.015

2.4.3 力学性能 Mechanical Properties

牌号 Grade	下屈服强度 R _{eL} /MPa Lower yield strength	抗拉强度 R _m /MPa Tensile strength	断后伸长率 Elongation		180°弯曲试验 b=35mm 180° Bending Test Width b=35mm	
			A _{80mm} /%	A/%	厚度 Thickness ≤ 12mm	厚度 Thickness > 12mm
			厚度 Thickness < 3mm	厚度 Thickness ≥ 3mm		
370L	≥ 245	370 ~ 480	≥ 23	≥ 28	D=0.5a	D=1a
420L	≥ 305	420 ~ 540	≥ 21	≥ 26	D=0.5a	D=1a
440L	≥ 330	440 ~ 570	≥ 21	≥ 26	D=0.5a	D=1a
510L	≥ 355	510 ~ 650	≥ 20	≥ 24	D=1a	D=2a
550L	≥ 400	550 ~ 700	≥ 19	≥ 23	D=1a	D=2a
600L	≥ 500	600 ~ 760	≥ 15	≥ 18	D=1.5a	D=2a
650L	≥ 550	650 ~ 820	≥ 13	≥ 16	D=1.5a	D=2a
700L	≥ 600	700 ~ 880	≥ 12	≥ 14	D=2a	D=2.5a
750L	≥ 650	750 ~ 950	≥ 11	≥ 13	D=2a	D=2.5a
800L	≥ 700	800 ~ 1000	≥ 10	≥ 12	D=2a	D=2.5a

2.4.4 可订货规格 Available size

标准号 standard	名称 Name	厚度订货范围 /mm Nominal thickness/ mm	宽度订货范围 /mm Nominal width/mm
	牌号 Grade		
GB/T 3273	370L、420L、440L、510L、550L	1.2-6.0	750-1300
	600L、650L、700L、750L、800L	1.5-6.0	

2.5 先进高强度钢 Advanced high-strength steel

先进高强度钢区别于传统高强度钢，具有良好吸能性，在汽车轻量化和提高安全性方面起着非常重要的作用。主要包括双相钢、复相钢、高扩孔钢，以及热成形钢。

首钢先进高强度钢广泛应用于汽车工业，主要应用于汽车结构件、安全件和加强件如 A/B/C 柱、车门槛、前后保险杠、车门防撞梁、横梁、纵梁、座椅滑轨等零部件。

Advanced high-strength steel is different from traditional high-strength steel, has good energy absorption, and plays a very important role in reducing the weight of automobiles and improving safety. Mainly include dual-phase steel, complex-phase steel, high hole expansion steel, and hot-formed steel.

Shougang's advanced high-strength steel is widely used in the automotive industry, mainly in automotive structural parts, safety parts and reinforcements such as A/B/C pillars, door sills, front and rear bumpers, door anti-collision beams, cross beams, longitudinal beams, seat slides Parts such as rails.



2.5.1 牌号标准 Grade and standard

标准号 Standard	先进高强度钢类别 Types of advanced high-strength steel	牌号 Grade
GB T 20887.3	Dual-phase steel 双相钢	HR300/540DP、HR330/580DP、HR380/680DP、HR450/780DP
GB T 20887.6	Complex-phase steel 复相钢	HR660/760CP、HR720/950CP
Q/SGJS 0018.1		HR800CP、HR1000CP
GB T 20887.2	High hole expansion steel 高扩孔钢	HR300/450HE、HR380/540HE、HR440/580HE、HR520/680HE、HR600/780HE、HR780/980HE
Q/SGJS 0018.2		FB590、FB780、FB45、FB60
协议	Nano Precipitation Steel 纳米析出钢	HR780NA、HR980NA

2.5.2 化学成分 Chemical composition

1. 双相钢 Dual-phase steel

牌号 Grade	化学成分 (熔炼分析) /% Chemical composition(wt%) (Ladle analysis)											
	C	Si	Mn	P	S	Alt	Cr+Mo	Nb+Ti	V	B	Cu	Cr+Ni+Mo
HR300/450DP	≤ 0.23	≤ 2.00	≤ 3.30	≤ 0.090	≤ 0.015	≥ 0.015	≤ 1.00	≤ 0.15	≤ 0.15	≤ 0.006	≤ 0.40	≤ 1.50
HR330/580DP												
HR380/680DP												
HR450/780DP												

2. 复相钢 Complex-phase steel

牌号 Grade	化学成分 (熔炼分析) Chemical composition(wt%) (Ladle analysis) /%									
	C	Si	Mn	P	S	Alt	Cr+Mo	Nb+Ti	V	B
HR660/760CP	≤ 0.15	≤ 0.80	≤ 2.20	≤ 0.040	≤ 0.015	≤ 2.00	≤ 1.00	≤ 0.20	≤ 0.20	≤ 0.005
HR720/950CP	≤ 0.20	≤ 1.50	≤ 2.50	≤ 0.040	≤ 0.015	≤ 2.00	≤ 1.20	≤ 0.20	≤ 0.20	≤ 0.005

牌号 Grade	化学成分 (熔炼分析) Chemical composition(wt%) (Ladle analysis) /%										
	C	Si	Mn	P	S	Alt	Cr+Mo	Nb+Ti	V	B	CU
HR800CP	≤ 0.18	≤ 0.8	≤ 2.2	≤ 0.08	≤ 0.015	≤ 2.0	≤ 1.0	≤ 0.25	≤ 0.20	≤ 0.005	≤ 0.20
HR1000CP	≤ 0.23	≤ 0.8	≤ 2.2	≤ 0.08	≤ 0.015	≤ 2.0	≤ 1.0	≤ 0.25	≤ 0.20	≤ 0.005	≤ 0.20

3. 高扩孔钢 High hole expansion steel

牌号 Grade	化学成分 (熔炼分析) Chemical composition(wt%) (Ladle analysis) /%										
	C	Si	Mn	P	S	Alt	Cr+Mo	Nb+Ti	V	B	Cr+Ni+Mo
HR300/450HE	≤ 0.18	≤ 1.00	≤ 2.00	≤ 0.050	≤ 0.010	≥ 0.015	≤ 1.00	≤ 0.15	≤ 0.15	≤ 0.005	≤ 1.50
HR380/540HE	≤ 0.18	≤ 1.20	≤ 2.00	≤ 0.050	≤ 0.010	≥ 0.015	≤ 1.00	≤ 0.15	≤ 0.15	≤ 0.010	≤ 1.50
HR440/580HE	≤ 0.18	≤ 1.20	≤ 2.00	≤ 0.050	≤ 0.010	≥ 0.015	≤ 1.00	≤ 0.15	≤ 0.15	≤ 0.010	≤ 1.50
HR520/680HE	≤ 0.18	≤ 1.20	≤ 2.00	≤ 0.050	≤ 0.010	≥ 0.015	≤ 1.00	≤ 0.15	≤ 0.15	≤ 0.010	≤ 1.50
HR600/780HE	≤ 0.18	≤ 1.20	≤ 2.00	≤ 0.050	≤ 0.010	≥ 0.015	≤ 1.00	≤ 0.15	≤ 0.15	≤ 0.010	≤ 1.50
HR780/980HE	≤ 0.18	≤ 1.60	≤ 2.20	≤ 0.050	≤ 0.010	≥ 0.015	≤ 1.00	≤ 0.15	≤ 0.15	≤ 0.010	≤ 1.50

牌号 Grade	化学成分 (熔炼分析) Chemical composition(wt%) (Ladle analysis) /%									
	C	Si	Mn	P	S	Alt	Nb	Ti	V	Cr
FB590	≤ 0.15	≤ 1.20	≤ 2.00	≤ 0.025	≤ 0.010	≥ 0.015	≤ 0.09	≤ 0.09	≤ 0.15	≤ 0.80
FB780	≤ 0.10	≤ 1.20	≤ 2.00	≤ 0.020	≤ 0.010	≥ 0.015	≤ 0.10	≤ 0.10	≤ 0.15	≤ 1.00
FB45	≤ 0.18	≤ 0.20	≤ 1.20	≤ 0.025	≤ 0.010	0.015-0.07	≤ 0.03	≤ 0.03	≤ 0.06	≤ 0.10
FB60	≤ 0.18	≤ 0.45	≤ 1.60	≤ 0.025	≤ 0.010	0.015-0.07	≤ 0.09	≤ 0.09	≤ 0.06	≤ 0.10

^a 经供需双方协商，也可以添加 Mo。

4. 纳米析出钢 Nano Precipitation Steel

牌号 Grade	化学成分 (熔炼分析) /% Chemical composition(wt%) (Ladle analysis)										
	C	Si	Mn	P	S	Alt	Ti	Mo	V	B	Cr+Ni+Mo
HR780NA	≤ 0.10	≤ 0.2	≤ 2.0	≤ 0.03	≤ 0.015	≥ 0.015	≤ 0.15	≤ 0.4	≤ 0.15	≤ 0.005	≤ 1.50
HR980NA	≤ 0.10	≤ 0.3	≤ 2.5	≤ 0.03	≤ 0.015	≥ 0.015	≤ 0.25	≤ 0.6	≤ 0.15	≤ 0.010	≤ 1.50

2.5.3 力学性能

1. 双相钢 Dual-phase steel

牌号 Grade	拉伸试验 Tensile test			
	下屈服强度 R _{eL} /MPa Lower yield strength R _{eL} /MPa	抗拉强度 R _m /MPa Tensile strength R _m /MPa	断后伸长率 % Elongation/%	
			A _{50mm} (L ₀ =50mm, b ₀ =25mm)	A _{80mm} (L ₀ =80mm, b ₀ =20mm)
HR300/450DP	330~450	540~660	≥ 24	≥ 21
HR330/580DP	330~450	580~700	≥ 22	≥ 19
HR380/680DP	380~500	680~800	≥ 19	≥ 17
HR450/780DP	450~610	780~900	≥ 16	≥ 14

2. 复相钢 Complex-phase steel

牌号 Grade	拉伸试验 Tensile test			
	下屈服强度 R_{eL} /MPa Upper yield strength R_{eL} /MPa	抗拉强度 R_m /MPa Tensile strength R_m /MPa	断后伸长率 A_{80mm} /% Elongation/%	
			板厚 /mm Thickness/mm	
			< 3.0	≥ 3.0
HR660/760CP	660~820	≥ 760	≥ 9	≥ 10
HR720/950CP	720~920	≥ 950	≥ 8	≥ 9

牌号 Grade	规定延伸强度 yield strength $R_{p0.2}$ /MPa	抗拉强度 Tensile strength R_m /MPa	断后伸长率 A_{80mm} /% Elongation/%
HR800CP	680-830	780-980	≥ 10
HR1000CP	720-920	950-1150	≥ 9

3. 高扩孔钢 High hole expansion steel

牌号 Grade	拉伸试验				平均极限 扩孔率 average limiting hole expansion ratio $\bar{\lambda}$ / %
	下屈服强度 R_{eL} /MPa Upper yield strength R_{eL} /MPa	抗拉强度 R_m /MPa Tensile strength R_m /MPa	断后伸长率 A_{50mm} /% Elongation/% (L0=50mm, b=25mm)	断后伸长率 A_{80mm} /% Elongation/% (L0=80mm, b=20mm)	
HR300/450HE	300~400	450~550	≥ 27	≥ 24	≥ 80
HR380/540HE	380~540	540~660	≥ 19	≥ 17	≥ 80
HR440/580HE	440~600	580~700	≥ 17	≥ 15	≥ 75
HR520/680HE	520~700	680~800	≥ 16	≥ 13	≥ 60
HR600/780HE	600~800	780~900	≥ 15	≥ 12	≥ 55
HR780/980HE	780~1000	980~1120	≥ 10	≥ 7	≥ 30

牌号 Grade	拉伸试验 Tensile test				平均极限 扩孔率 average limiting hole expansion ratio $\bar{\lambda}$ / %
	下屈服强度 R_{eL} /MPa Lower yield strength R_{eL} /MPa	抗拉强度 R_m /MPa Tensile strength R_m /MPa	断后伸长率 /% Elongation /%		
			厚度 Thickness <3mm A_{80mm}	厚度 Thickness ≥ 3mm A	
FB590	480~620	590~670	≥ 16	21	≥ 70
FB780	680~840	780~900	≥ 12	15	≥ 50
FB45	320~410	450~560	≥ 24	31	≥ 80
FB60	460~570	580~700	≥ 16	21	≥ 75

4. 纳米析出钢 Nano Precipitation Steel

牌号 Grade	拉伸试验			平均极限 扩孔率 average limiting hole expansion ratio $\bar{\lambda}$ / %
	下屈服强度 R_{eL} /MPa Upper yield strength R_{eL} /MPa	抗拉强度 R_m /MPa Tensile strength R_m /MPa	断后伸长率 A_{50mm} /% Elongation/% (L0=50mm, b=25mm)	
HR780NA	680 ~ 830	≥ 780	≥ 17	≥ 65
HR980NA	780 ~ 1000	≥ 980	≥ 12	≥ 35

2.5.4 可订货规格 Available size

先进高强度钢 Advanced high-strength steel	牌号 Grade	厚度订货范围 /mm Nominal thickness/mm	宽度订货范围 /mm Nominal width/mm
双相钢 Dual-phase steel	HR330/540DP、HR330/580DP、HR380/680DP、HR450/780DP	1.2-6.0	750-1260
复相钢 Complex-phase steel	HR660/780CP、HR720/950CP、HR800CP、HR1000CP	2.0-6.0	800-1500
高扩孔钢 High hole expansion steel	HR300/450HE、HR380/540HE、HR440/580HE、HR520/680HE、HR600/780HE、HR780/980HE、FB590、FB780、FB45、FB60	1.8-5.0	800-1260
纳米析出钢 Nano Precipitation Steel	HR780NA、HR980NA	2.0-6.0	800-1500

2.6 热成形钢 Hot formed steel

热冲成形钢通过添加 Cr、B 等微合金元素提高钢板的淬透性，通过将钢板加热到奥氏体化温度以上，在模具内完成成形和淬火，将材料强度提高到 1300MPa 以上，有效提高零件的抗碰撞性能，实现车身轻量化，主要用于防止入侵的安全结构件。

The hardenability of hot formed steel is improved by adding some micro-alloyed elements such as Cr and B. The steel sheets are heated above the austenitizing temperature, deformed, and quenched in the die, and then the tensile strength can be increased to above 1300MPa. With this kind of mechanical properties, the anti-collision performance of parts is effectively improved and the lightweight of car body is realized. The steel is mainly used as safety structural parts, especially for anti-intrusion components.

2.6.1 牌号标准 Grade and standard

首钢企业标准 Shougang standard	相当国家标准 National standard
SGXYJ 0040	22MnB5、26MnB5、34MnB5 HR950/1300HS、HR1000/1500HS、HR1200/1800HS、HR1200/2000HS
	GB/T 34566-2017
	HR950/1300HS、HR1000/1500HS、HR1200/1800HS

2.6.2 化学成分 Chemical composition

牌号 Grade	化学成分 (熔炼分析) /% Chemical composition(wt%) (Ladle analysis)										
	C	Si ≤	Mn	P ≤	S ≤	Alt	B	Cr ≤	Ti	Mo ≤	N ≤
22MnB5	0.20-0.25	0.50	1.1-1.6	0.025	0.010	0.010-0.060	0.0008-0.0050	0.35	0.02-0.05	0.35	0.008
26MnB5	0.24-0.29	0.50	1.1-1.6	0.025	0.010	0.010-0.060	0.0008-0.0050	0.35	0.02-0.05	0.35	0.008
34MnB5	0.32-0.37	0.50	1.1-1.6	0.025	0.010	0.010-0.060	0.0008-0.0050	0.35	0.02-0.06	0.35	0.008
40MnB5	0.38-0.43	0.50	1.1-1.6	0.025	0.010	0.010-0.060	0.0008-0.0050	0.60	0.02-0.06	0.35	0.008
HR950/1300HS	0.17-0.25	0.50	1.0-1.6	0.025	0.010	0.010-0.060	0.0008-0.0050	0.35	0.02-0.06	0.35	0.008
HR1000/1500HS	0.20-0.26	0.50	1.0-1.6	0.025	0.010	0.010-0.060	0.0008-0.0050	0.35	0.02-0.06	0.35	0.008
HR1200/1800HS	0.27-0.35	0.50	1.1-2.0	0.025	0.010	0.010-0.060	0.0008-0.0050	0.50	0.02-0.06	0.35	0.008
HR1200/2000HS	0.32-0.40	0.50	1.1-2.0	0.025	0.010	0.010-0.060	0.0008-0.0050	1.00	0.02-0.06	0.35	0.008

2.6.3 力学性能 Mechanical Properties

牌号 Grade	拉伸试验 Tensile test		
	下屈服强度 R_{eL} /MPa Upper yield strength R_{eL} /MPa	抗拉强度 R_m /MPa Tensile strength R_m /MPa	断后伸长率 A_{50mm} /% Elongation/% ($L_0=50mm$, $b=25mm$)
22MnB5	320-630	480-800	≥ 15
26MnB5	320-650	500-800	≥ 14
34MnB5	320-680	550-850	≥ 12
40MnB5	350-780	600-950	≥ 10

牌号 Grade	拉伸试验 Tensile test		
	下屈服强度 R_{eL} /MPa Upper yield strength R_{eL} /MPa	抗拉强度 R_m /MPa Tensile strength R_m /MPa	断后伸长率 A_{50mm} /% Elongation/% ($L_0=50mm$, $b=25mm$)
HR950/1300HS	320-630	480-800	≥ 15
HR1000/1500HS	320-650	500-800	≥ 14
HR1200/1800HS	320-680	500-900	≥ 12
HR1200/2000HS	350-800	600-1000	≥ 10

2.6.4 可订货规格 Size supply

牌号 Grade	厚度 /mm thickness/mm	宽度 /mm width/mm
22MnB5、26MnB5、34MnB5	1.2-6.5	800-1520
HR950/1300HS、HR1000/1500HS、 HR1200/1800HS、HR1200/2000HS		

Chapter 3 Product specification and dimensional accuracy

第三章 产品规格及尺寸精度

表 1 规定最小屈服强度小于 360MPa 钢板和钢带的厚度允许偏差 单位为毫米
Table 1 The allowable deviation in millimeters for the thickness of steel plates and strips with a minimum yield strength of less than 360MPa (mm)

公称厚度 Nominal thickness/ mm	厚度允许偏差 Allowable deviation of thickness											
	普通精度 PT.A General precision				较高精度 PT.B High precision				高级精度 PT.C highest precision			
	公称宽度 Nominal width/mm				公称宽度 Nominal width/mm				公称宽度 Nominal width/mm			
	700 ~ 1200	> 1200 ~ 1500	> 1500 ~ 1800	> 1800	700 ~ 1200	> 1200 ~ 1500	> 1500 ~ 1800	> 1800	700 ~ 1200	> 1200 ~ 1500	> 1500 ~ 1800	> 1800
≤ 1.50	± 0.15	± 0.17	-	-	± 0.10	± 0.12	-	-	± 0.08	± 0.10	-	-
$> 1.50 \sim 2.00$	± 0.17	± 0.19	± 0.21	-	± 0.13	± 0.14	± 0.14	-	± 0.10	± 0.11	± 0.11	-
$> 2.00 \sim 2.50$	± 0.18	± 0.20	± 0.21	± 0.25	± 0.14	± 0.15	± 0.17	± 0.20	± 0.11	± 0.12	± 0.14	± 0.17
$> 2.50 \sim 3.00$	± 0.19	± 0.21	± 0.22	± 0.25	± 0.15	± 0.17	± 0.19	± 0.21	± 0.12	± 0.14	± 0.16	± 0.18
$> 3.00 \sim 4.00$	± 0.21	± 0.23	± 0.26	± 0.27	± 0.17	± 0.18	± 0.21	± 0.22	± 0.13	± 0.15	± 0.17	± 0.18
$> 4.00 \sim 5.00$	± 0.24	± 0.26	± 0.28	± 0.29	± 0.19	± 0.21	± 0.22	± 0.23	± 0.14	± 0.16	± 0.17	± 0.19
$> 5.00 \sim 6.00$	± 0.26	± 0.28	± 0.29	± 0.31	± 0.21	± 0.22	± 0.23	± 0.25	± 0.16	± 0.17	± 0.18	± 0.20
$> 6.00 \sim 8.00$	± 0.29	± 0.30	± 0.31	± 0.35	± 0.23	± 0.24	± 0.25	± 0.28	± 0.18	± 0.19	± 0.20	± 0.23
$> 8.00 \sim 10.00$	± 0.32	± 0.33	± 0.34	± 0.40	± 0.26	± 0.26	± 0.27	± 0.32	± 0.20	± 0.21	± 0.22	± 0.26
$> 10.00 \sim 12.50$	± 0.35	± 0.36	± 0.37	± 0.43	± 0.28	± 0.29	± 0.30	± 0.36	± 0.22	± 0.23	± 0.24	± 0.30
$> 12.50 \sim 15.00$	± 0.37	± 0.38	± 0.40	± 0.46	± 0.30	± 0.31	± 0.33	± 0.39	± 0.23	± 0.24	± 0.26	± 0.33
$> 15.00 \sim 25.40$	± 0.40	± 0.42	± 0.45	± 0.50	± 0.32	± 0.34	± 0.37	± 0.42	± 0.25	± 0.27	± 0.30	± 0.35

表 2 规定最小屈服强度不小于 360MPa 钢板和钢带的厚度允许偏差 单位为毫米
Table 2 The allowable deviation in millimeters for the thickness of steel plates and strips with a minimum yield strength of no less than 360MPa (mm)

公称厚度 Nominal thickness/ mm	厚度允许偏差 Allowable deviation of thickness											
	普通精度 PT.A General precision				较高精度 PT.B High precision				高级精度 PT.C Highest precision			
	公称宽度 Nominal width/mm				公称宽度 Nominal width/mm				公称宽度 Nominal width/mm			
	700 ~ 1200	> 1200 ~ 1500	> 1500 ~ 1800	> 1800	700 ~ 1200	> 1200 ~ 1500	> 1500 ~ 1800	> 1800	700 ~ 1200	> 1200 ~ 1500	> 1500 ~ 1800	> 1800
≤ 1.50	±0.17	±0.19	-	-	±0.11	±0.13	-	-	±0.09	±0.11	-	-
> 1.50 ~ 2.00	±0.19	±0.21	±0.23	-	±0.14	±0.15	±0.15	-	±0.11	±0.12	±0.12	-
> 2.00 ~ 2.50	±0.20	±0.23	±0.25	±0.28	±0.15	±0.17	±0.19	±0.22	±0.12	±0.14	±0.16	±0.19
> 2.50 ~ 3.00	±0.22	±0.24	±0.26	±0.29	±0.17	±0.19	±0.21	±0.23	±0.14	±0.15	±0.18	±0.20
> 3.00 ~ 4.00	±0.24	±0.26	±0.29	±0.30	±0.19	±0.20	±0.23	±0.24	±0.15	±0.16	±0.19	±0.20
> 4.00 ~ 5.00	±0.26	±0.29	±0.31	±0.32	±0.21	±0.23	±0.24	±0.25	±0.16	±0.18	±0.19	±0.21
> 5.00 ~ 6.00	±0.29	±0.31	±0.32	±0.34	±0.23	±0.24	±0.25	±0.28	±0.18	±0.19	±0.20	±0.23
> 6.00 ~ 8.00	±0.32	±0.33	±0.34	±0.39	±0.25	±0.26	±0.28	±0.31	±0.20	±0.21	±0.23	±0.26
> 8.00 ~ 10.00	±0.35	±0.36	±0.37	±0.44	±0.29	±0.29	±0.30	±0.35	±0.23	±0.24	±0.25	±0.29
> 10.00 ~ 12.50	±0.39	±0.40	±0.41	±0.47	±0.31	±0.32	±0.33	±0.40	±0.25	±0.26	±0.27	±0.34
> 12.50 ~ 15.00	±0.41	±0.42	±0.44	±0.51	±0.33	±0.34	±0.36	±0.43	±0.26	±0.27	±0.29	±0.36
> 15.00 ~ 25.40	±0.44	±0.46	±0.50	±0.55	±0.35	±0.37	±0.41	±0.46	±0.28	±0.30	±0.34	±0.39

表 3 钢板和钢带的宽度允许偏差 单位为毫米
Table 3 The allowable deviation in millimeters for the thickness of steel plates and strips

公称宽度 Nominal thickness/mm	允许偏差 Allowable deviation	
	切边 Scrap edge	不切边 Mill-edge
≤ 1200	+ 3 0	+ 20 0
> 1200 ~ 1500	+ 5 0	
> 1500	+ 6 0	

Chapter 4 Quality assurance

第四章 质量保障

- 通过 ISO9001 质量体系认证。
- 通过了 ISO/IEC17025:2005 实验室认证。
- 通过了 GBT19002-2003/ISO10012:2003 测量体系的认证。
- 通过了 ISO/TS16949: 2009, GB/T24001-2004 /ISO14001:2004, GB/T28001-2011 体系认证审核。
- Shougang obtained ISO 9001 certification.
- Shougang obtained ISO/IEC17025:2005 laboratory certification.
- Shougang obtained GBT19002-2003/ISO10012:2003 measurement system certification .
- Shougang obtained ISO/TS16949:2009, GB/T24001-2004/ISO14001:2004, GB/T28001-2011 system certification .



Chapter 5 Packaging and Labeling

第五章 包装与标识

表 4 包装方式分类 Table 1 Classification of packing methods

类别 Category	包装方式代码 Packing Code	包装方式名称 Name of packing method	适用范围 Range of application	
			一般要求 General requirements	其他要求 Other requirements
热连轧酸洗钢带 Hot rolled pickled steel strip	HP01	Simple package	筒包适用于储运条件较好、短途运输、直接用户、气候条件较好或产品表面质量要求不高等情况； Simple package is suitable for conditions such as good storage and transportation conditions, short-distance transportation, direct users, good weather conditions or low product surface quality requirements; 普包适用于储运条件复杂、中长途运输、周转运输、气候条件一般或产品表面质量要求较高等情况； The general package is suitable for complicated storage and transportation conditions, long-distance transportation, turnover transportation, general climatic conditions or high product surface quality requirements, etc.; 精包适用于储运条件复杂、长途运输、出口、气候条件较差或产品表面质量要求很高等情况。 Fine packaging is suitable for complex storage and transportation conditions, long-distance transportation, export, poor weather conditions, or high product surface quality requirements.	适用于国内，主要用于冷轧原材料的包装。此包装为裸装，为避免争议，需向客户说明可能带来的影响。 Applicable to domestic, mainly used for packaging of cold-rolled raw materials. This packaging is naked, in order to avoid disputes, it is necessary to explain the possible impact to the customer.
	HP03	Simple package		适用于国内。 Applicable to domestic.
	HP04	General package		适用于国内。 Applicable to domestic.
	HP04a	General package		适用于国内。 Applicable to domestic.
	HP05	Fine package		适用于国内和出口。 Suitable for domestic and export.
	HP05a	Fine package		适用于国内和出口。 Suitable for domestic and export.
	HP06	Fine package		适用于国内和出口。 Suitable for domestic and export.
热连轧酸洗钢板 Hot rolled pickled steel plate	HPS01	General package	适用于国内。 Applicable to domestic.	
	HPS02	Fine package	适用于国内和出口。 Suitable for domestic and export.	
	HPS03	Fine package	适用于国内和出口。 Suitable for domestic and export.	

1、热连轧酸洗钢带包装方式 Packing method of hot-rolled pickled steel strip

表 5 热连轧酸洗钢带包装方式 Table 2 Classification of packing methods

序号 Number	包装方式名称 Name of packing method	包装方式代码 Packing Code	气相防锈纸 volatile rust preventive paper	内芯纸板 The cardboard inner core	工业膜 Industrial film	内周护板 Inner peripheral guard plate		外周护板 Outer peripheral guard plate				端护板 End guard plate		护角 Guard corner		钢捆带 Steel strap	推荐方式图示 Recommended way diagram
						瓦楞纸 corrugated paper	钢 Steel	瓦楞纸 corrugated paper	纤维 fiber	钢 Steel	塑料 plastic	纸 paper	钢 Steel				
1	筒包 Simple package	HP01	-	-	-	-	-	-	-	-	-	-	-	-	-	√	图 1 Figure 1
2	筒包 Simple package	HP03	√	√	-	-	-	-	-	-	-	-	√	√	-	√	图 2 Figure 2
3	普包 General package	HP04	√	√	-	-	√	-	√	-	√	√	√	√	-	√	图 3 Figure 3
4	普包 General package	HP04a	√	√	-	-	√	-	-	√	√	√	√	√	-	√	图 3 Figure 3
5	精包 Fine package	HP05	√	√	√	-	√	-	√	-	√	√	√	√	-	√	图 4 Figure 4
6	精包 Fine package	HP05a	√	√	√	-	√	-	-	√	√	√	√	√	-	√	图 4 Figure 4
7	精包 Fine package	HP06	√	√	√	√	√	√	-	√	√	√	√	√	-	√	图 5 Figure 5



图 1 HP01 包装图示
Fig.1 HP01 Packing diagram



图 3 HP04,HP04a 包装图示
Fig.3 HP04,HP04a Packing diagram

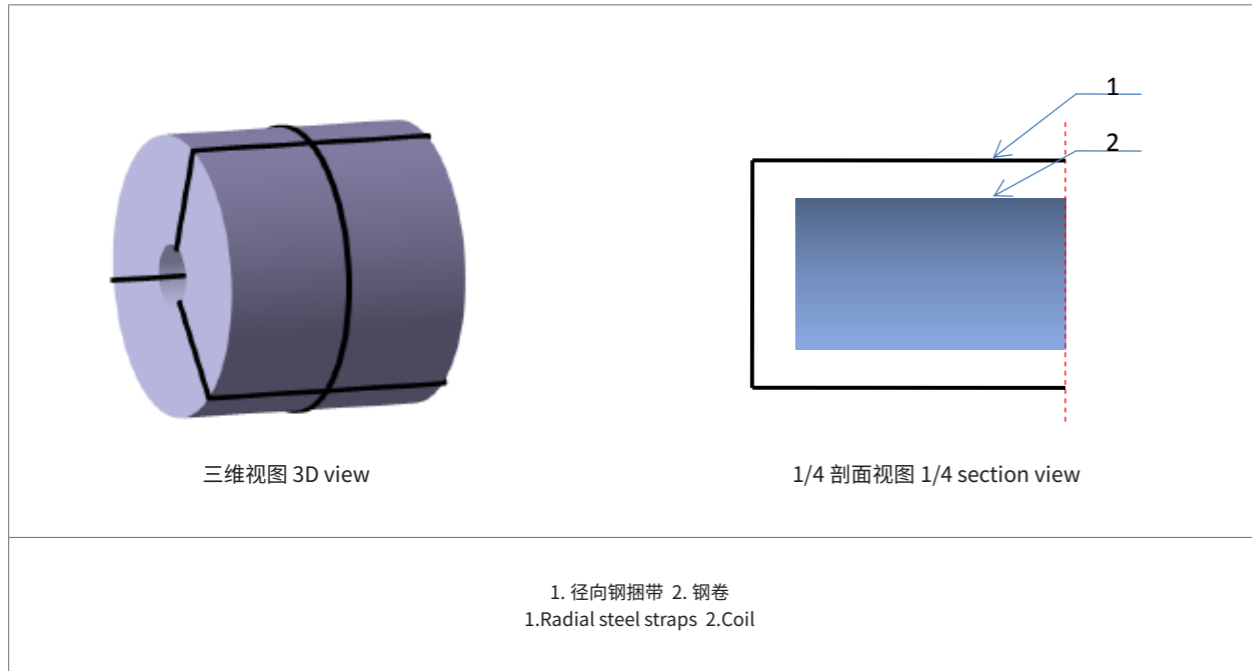

图 2 HP03 包装图示
Fig.2 HP03 Packing diagram

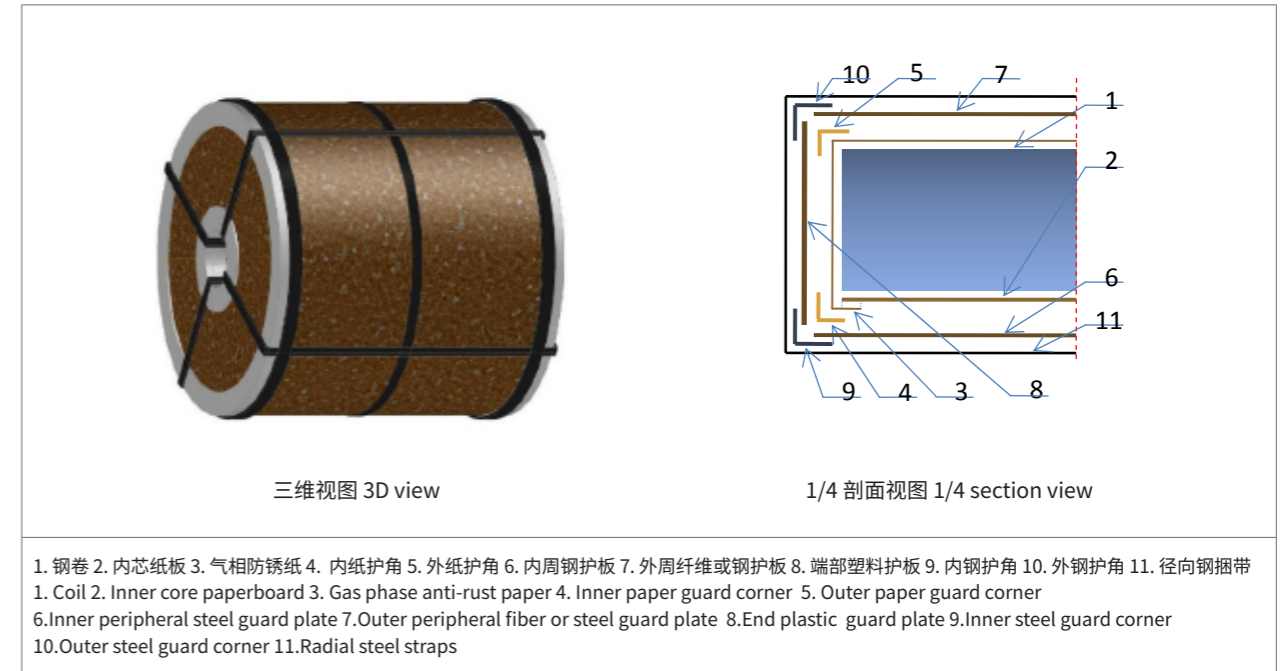

图 4 HP05,HP05a 包装图示
Fig.4 HP05,HP05a Packing diagram

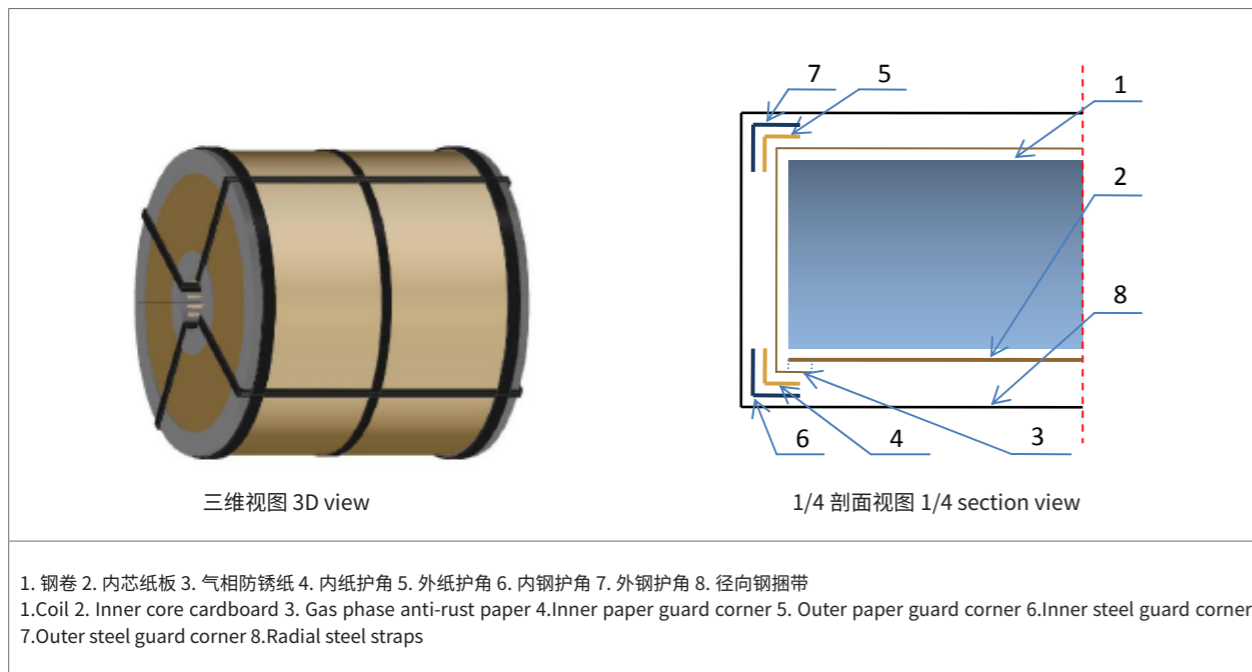

图 5 HP06 包装图示
Fig.5 HP06 Packing diagram

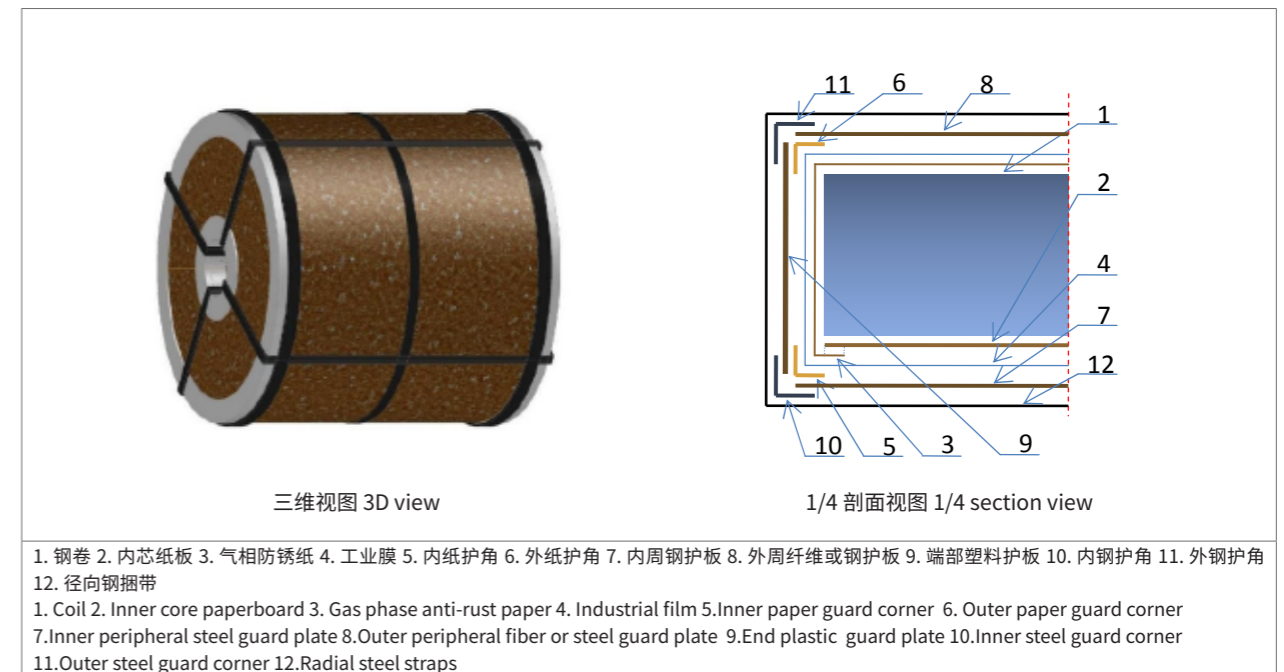

图 6 HPS01 包装图示
Fig.6 HPS01 Packing diagram

2、热连轧酸洗钢板的包装方式 Packing method of hot-rolled pickled steel plate

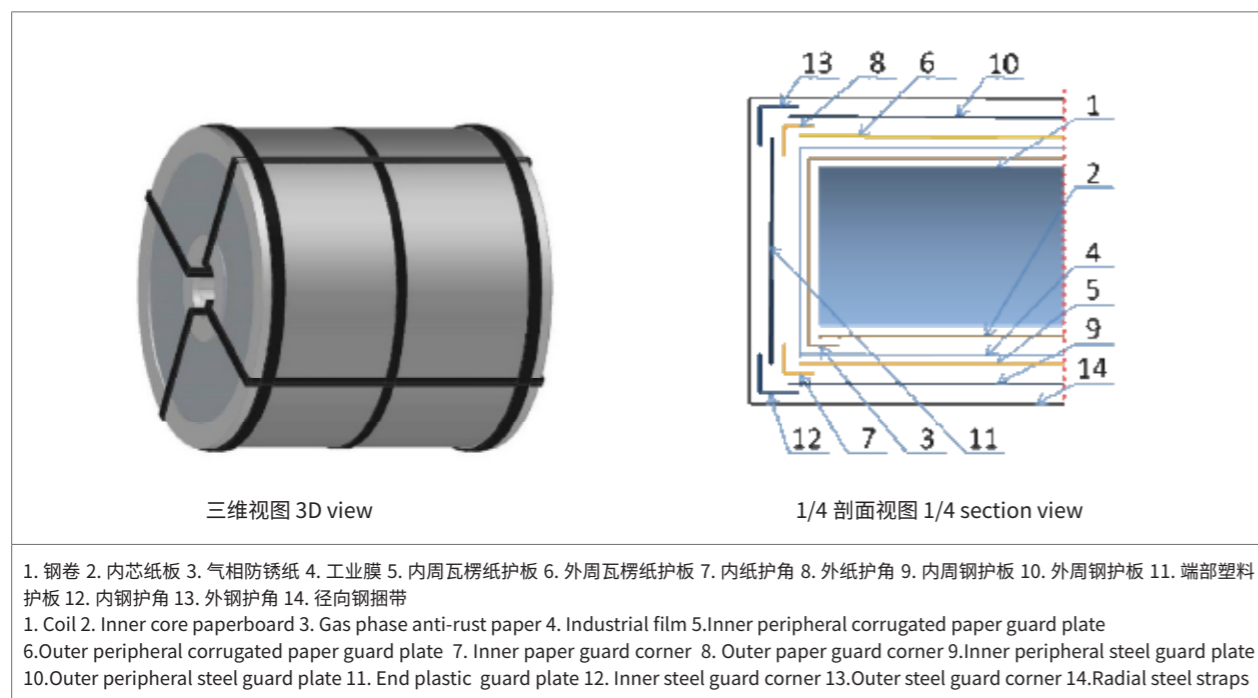
表 6 热连轧酸洗钢板的包装方式 Table 3 Classification of packing methods

序号 Number	包装方式名称 Name of packing method	包装方式代码 Packing Code	气相防锈纸 volatile rust preventive paper	工业膜 Industrial film	下垫板 Underlay backing plate	上盖板 Upper cover plate	侧护板 Side guard plate	钢质托架 Steel bracket	钢护角 Steel guard corner	盒盖 Box cover	围板 Coaming	钢捆带 Steel strap	推荐方式图示 Recommended way diagram
1	普包 General package	HPS01	✓	✓	-	-	-	✓	✓	-	-	纵向不小于2道, 横向不小于3道 Not less than 2 lines longitudinal, not less than 3 lines transverse	图 6 figure 6
2	精包 Fine package	HPS02	✓	✓	✓	✓	✓	✓	✓	-	-	纵向不小于2道, 横向不小于3道 Not less than 2 lines longitudinal, not less than 3 lines transverse	图 7 figure 7
3	精包 Fine package	HPS03	✓	✓	-	-	-	✓	-	✓	✓	纵向不小于2道, 横向不小于3道 Not less than 2 lines longitudinal, not less than 3 lines transverse	图 8 figure 8

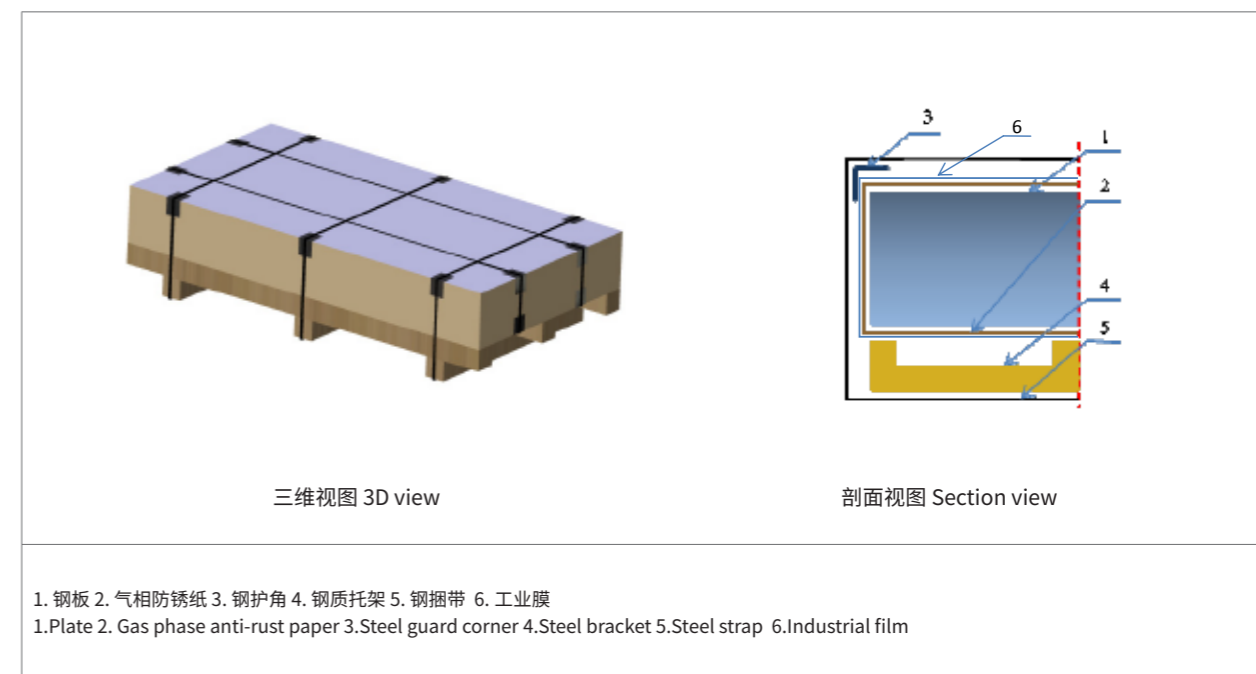

图 7 HPS02 包装图示
Fig.7 HPS02 Packing diagram



图 8 HPS03 包装图示
Fig.8 HPS03 Packing diagram

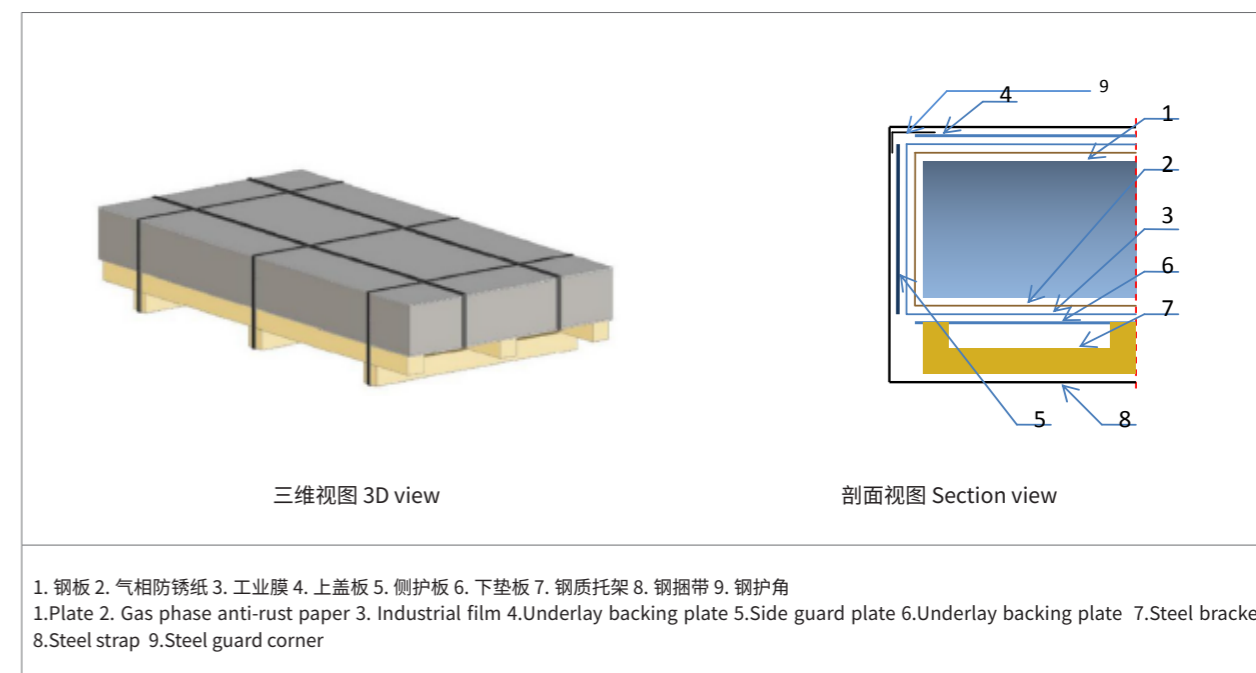

北京首钢股份有限公司
Beijing Shougang Co.,Ltd.
<http://www.sggf.com.cn>

首钢智慧营销平台
Shougang Intelligent Marketing Platform
<https://imp.sggf.com.cn>

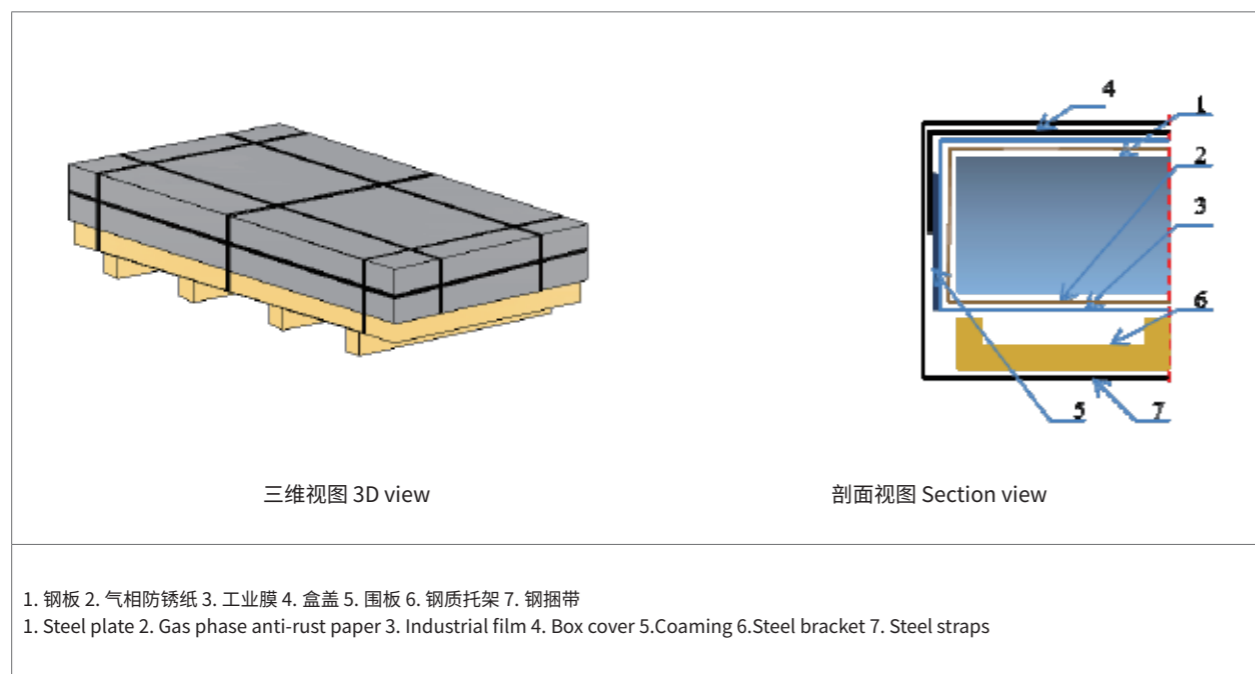
上海首钢钢铁贸易有限公司
Shanghai Shougang Steel Trading Co. Ltd.
电话: 021-50930789
传真: 021-50931008

天津首钢钢铁贸易有限公司
Tianjin Shougang Steel Trade Co., Ltd.
电话: 022-84914552
传真: 022-84918191

广州首钢钢铁贸易有限公司
Guangzhou Shougang Steel Trade Co., Ltd.
电话: 020-22123069
传真: 020-22123691

武汉首钢钢铁贸易有限公司
Wuhan Shougang Steel Trade Co., Ltd.
电话: 027-59710209
传真: 027-59710258

山东首钢钢铁贸易有限公司
Shandong Shougang Steel Trade Co., Ltd.
电话: 0532-80667080
传真: 0532-80667087

首钢鹏龙钢材有限公司
电话: 010-81470116

佛山首钢中金钢材加工配送有限公司
电话: 0757-81861600

苏州首钢钢材加工配送有限公司
电话: 0512-53995377

首钢(青岛)钢业有限公司
电话: 0532-86682569

宁波首钢浙金钢材有限公司
电话: 0574-86283086

株洲首钢汇隆钢材加工配送有限公司
电话: 0731-22330180

宁波首钢汽车部件有限公司
电话: 0574-23455501

天津物产首钢钢材加工配送有限公司
电话: 022-59060812

哈尔滨首钢武中钢材加工配送有限公司
电话: 0451-51640025

重庆首钢武中汽车部件有限公司
电话: 023-63173616

沈阳首钢钢材加工配送有限公司
电话: 024-83960710

中国首钢印度有限公司
China Shougang India Private Limited
Tel: 0091 124 4100380/1
Tax: 0091 124 4100381

首钢国际(马来西亚)有限公司
Shougang International(Malaysia)SDN.BHD.
Tel: 0060 03 33778968/8972
Tax: 0060 03 33920293

首钢国际(新加坡)有限公司
Shougang International(Singapore) PTE. Limited
Tel: 0065 62251706
Tax: 0065 62252617

首钢国际(韩国)有限公司
Shougang International(Korea)CO.,LTD
Tel: 0082 220519118
Tax: 0082 517459117

首钢国际(奥地利)有限公司
Shougang International(Austria)GmbH
Tel: 0043 1 802 1995 10
Tax: 0043 1 802 1995 50

首钢国际(香港)投资有限公司
Shougang International(Hong Kong) Investment Limited
Tel: 00852- 28910011
Tax: 00852- 28910011

首钢国际(加拿大)投资有限公司
Shougang International(Canada)Investment LTD.
Tel: 001 6046970128
Tax: 001 6046970113

卓航海运(新加坡)有限公司
Superior Ocean Shipping(Singapore)PTE.LTD.
Tel: 0065-62251706
Tax: 0065-62252617

产品商标介绍

PRODUCT TRADEMARK INTRODUCTION

注册商标	商标名称	商标简述	主要牌号
SOVETEN®	首钢超高强汽车板 Ultra High Strength Steel	<p>抗拉强度超过 780MPa 级别的超高强钢，产品覆盖酸洗及冷轧双相钢 (DP)，热基、酸洗及冷轧复相钢 (CP)、冷轧马氏体钢 (MS) 等，广泛应用于车身及底盘安全结构件，可实现汽车轻量化的同时提升碰撞安全性能。</p> <p>Ultra high strength steel with a tensile strength exceeding 780MPa, including dual phase steel (DP)(pickled or cold rolled), complex phase steel (CP)(hot rolled, pickled or cold rolled), martensitic steel (MS) (cold rolled), etc., are widely used in body and chassis safety structural parts, can reduce the weight of the car and improve the crash safety performance.</p>	HRMP800、HR800CP、HR1000CP、HR660Y760T-CP、HR450/780DP、SP251-780FPQ、SP251-780PQ、WSS-M1A368-A71 等
SOVEWH®	首钢车轮钢 Wheel Steel	<p>首钢车轮钢热轧板卷，采用不同强化方式设计形成普通碳锰、高强低合金、低温相变强化三大系列产品，具有良好的焊接性能、成形性能和疲劳性能，尺寸精度高、表面质量优异，广泛应用于国内外不同轻量化水平的商用车、乘用车车轮轮辋和轮辐制造。</p> <p>The continuously hot rolled steel sheet and strip for automobile wheel were designed with different strengthening processes to form three series of products: C-Mn, HSLA and low-temperature transformation hardening steels. With good weldability, formability and fatigue performance, high precision of dimension and outstanding surface quality, the products are widely used in the manufacturing of domestic and overseas commercial and passenger automobile wheel rims and discs with different lightweight levels.</p>	S380LW、S420LW、S490LW、SHR590DP、SHR590FB、SHR590HE、SHR650DP、SHR650FB、SHR690DP、SHR690FB、SHR700FB、SHR780FB、SHR800DP、SPFH540、SRS590、SRS650 等
SOHILAM®	首钢高扩孔高强汽车板 High Strength Steel with High Hole Expansion Ratio	<p>高扩孔高强钢是具有优异扩孔性能的钢种，产品覆盖冷轧高扩孔钢、酸洗及热基高扩孔钢，冷轧高扩孔钢应用于车身安全结构件，有利于提高车身结构抗侵入性能，提升承载吸能效果；热轧高扩孔钢具有优异的边缘延展性及疲劳耐久性，广泛应用于底盘复杂结构件。</p> <p>High hole expansion high strength steel is a steel with excellent hole expansion performance including cold rolled, pickled and hot rolled. Cold rolled high hole expansion steel is used to manufacture body safety structural parts. It is conducive to improve the anti-intrusion performance of the body structure and the load-bearing and energy-absorbing effect. Hot rolled high hole expansion steel has excellent edge ductility and fatigue durability, which is widely used in complex structural parts of the chassis.</p>	HR480Y580T-HED、HR660Y760T-HED、HR600/780HE、HR300/450HE、HR380/540HE、HR440/580HE、HR440/590HE、HR450T/300Y-FB、HR580T/440Y-FB、HR440Y580T-FB、HR300Y450T-FB、HRFB600、FB780、FB45、FB60、HR45、HR60 等



首钢智慧营销平台
Shougang for WeChat



扫描下载本册内容
Scan QR code to download this file

北京首钢股份有限公司
Beijing Shougang Co.,Ltd.



本手册以环保纸印刷
Using the recyclable paper

SGGF 2023-06-01-004



6 787604 117412